

Original Operating manual

1-980-001-BL_en



Elevator Tipper HK1200



CONTENTS

1	PRODUCT INFORMATION.....	1
1.1	GENERAL INFORMATION.....	1
1.2	SAFETY ADVICES AND SYMBOLS.....	1
1.3	MANUFACTURERS ADDRESS	2
1.4	WARRANTY AND LIABILITY	2
1.5	DESIGNATION OF TYPES.....	3
1.6	VERSION ADMINISTRATION	3
2	SAFETY	3
2.1	INTENDED USE OF THE MACHINE	4
2.2	REASONABLY FORESEEN MISUSE	5
2.3	ATEX – ZONE CONCEPT	5
2.4	EXTERNAL MACHINE- / PLANT COMPONENTS.....	5
2.5	HAZARDOUS AREAS ON THE ELEVATOR TIPPER HK1200	6
2.6	WARNING SIGNS ON THE MACHINE	8
2.7	SAFETY DEVICES AT THE ELEVATOR TIPPER HK1200.....	10
2.8	RESPONSABILITY OF THE OPERATING COMPANY.....	16
3	MACHINE OVERVIEW.....	22
3.1	TECHNICAL SPECIFICATION DIOSNA ELEVATOR TIPPER HK1200	22
3.2	TECHNICAL DATA DIOSNA ELEVATOR TIPPER HK1200.....	25
3.3	PERMITTED AMBIENT CONDITIONS	26
3.4	DIMENSIONS ELEVATOR TIPPER MACH.-SER. -NO. SEE TYPE PLATE.....	26
4	TRANSPORT AND SETTING UP.....	28
4.1	UNLOADING AND TRANSPORT	28
4.2	SETTING UP	30
4.3	CONNECTING	33
5	SETTING INTO OPERATION.....	34
5.1	BEFORE SETTING INTO OPERATION	34
5.2	SETTING INTO OPERATION	34
5.3	RESTART AFTER STOPPING	36
6	OPERATION.....	37
6.1	DESCRIPTION OF THE MACHINE / SYSTEM'S FUNCTIONS ELEVATOR TIPPER HK1200	37
6.2	DRIVING THE BOWL TROLLEY INTO THE ELEVATOR TIPPER	38
6.3	PUSH-BUTTON CONTROL WITH iTIMERN (EXECUTION D)	39
6.4	SECURITY CHECK.....	40
6.5	CUT OFF IN AN EMERGENCY SITUATION	41
7	CLEANING	42
7.1	GENERAL ASPECTS OF HYGIENE RISK.....	42
7.2	CLEANING OF THE MACHINE	43
7.3	MACHINE AREAS THAT ARE DIFFICULT TO ACCESS	45
7.4	CLEANING AGENTS.....	45
8	SERVICING AND MAINTENANCE INSTRUCTIONS	47
8.1	GENERAL INFORMATION.....	47
8.2	SAFETY INSTRUCTIONS	48

8.3	SECURITY CHECK	51
8.4	MAINTENANCE PLAN ELEVATOR TIPPER HK1200	52
8.5	MAINTENANCE OF THE HYDRAULIC SYSTEM	54
8.6	NOTES FOR THE (OPTIONAL) LIGHT CURTAIN.....	55
8.7	LUBRICANTS	62
8.8	WEB-LINKS TO THE SUPPLIERS DOCUMENTATIONS	63
9	FINAL SHUTDOWN AND DISPOSAL.....	64
9.1	SHUTDOWN.....	64
9.2	FINAL SHUTDOWN AND DISPOSAL.....	64
10	TROUBLESHOOTING	66

1 PRODUCT INFORMATION

1.1 GENERAL INFORMATION

These Operating manual are a part of the product and include all the information necessary for the set-up, start-up, the operation, maintenance, repair and disposal of the described machine.



NOTICE!

These Operating manual must be accessible at all times in a complete and legible condition.

They must be read and understood prior to any work on the machine.



This Elevator Tipper HK1200 was designed and constructed according to the current state of the art and in compliance with the accepted safety regulations.

In addition to these Operating manual, general statutory and other mandatory regulations for industrial safety and environmental protection must be observed and be directed!



NOTICE!

In the scope of machinery directive 2006/42/EC, it is forbidden to put a machine without a valid declaration of conformity into operation.

1.2 SAFETY ADVICES AND SYMBOLS



DANGER!

Ignoring the warning will lead to dangerous situations that will result in death or severe injury.



WARNING!

Ignoring the warning will lead to dangerous situations that will result in severe injury.

**CAUTION!**

Ignoring the warning will lead to dangerous situations that will result in slight or average injury.

**NOTICE!**

Ignoring the warning will lead to environmental damage, property damage or damage to the machine.

**NOTE!**

Advice and information

1.3 MANUFACTURERS ADRESS



DIOSNA Dierks & Söhne GmbH
 D – 49009 Osnabrück, Postfach 1980
 D – 49086 Osnabrück, Am Tie 23
 Phone: +49 (541) 33104 – 0
 Fax: +49 (541) 33104 – 10
 E-Mail: info@diosna.de
 Web: www.diosna.com

1.4 WARRANTY AND LIABILITY

Generally, our „General Terms and Conditions“ shall apply.

DIOSNA Dierks & Söhne GmbH excludes warranty and liability claims for personal injury and property damage, if they are due to one or some of the following reasons:

- Not intended use
- Improper assembly, commissioning, operation
- Nonobservance of the information, instructions, prohibitions in the Operating Instructions
- Unauthorised structural changes of the plant
- Improperly performed repair works

If damages occur due to nonobservance of the Operating Instructions, the warranty claim will expire. We shall not be liable for consequential damages that result from these.

1.5 DESIGNATION OF TYPES

DESIGNATION OF TYPES

HK1200	NNNNN-XXXX	DIOSNA elevator tipper	
	HK	Elevator tipper HK(V) type	
	170 224 300 600 1000 1200	Type number	
NNNNN	00049 00921 00920 00034 00044 00120 00984	Machine type number	HK 170 HK 224 HKV 224 HK 300 HK 600 HK 1000 HK 1200
	XXXX	Machine serial number	

OPTIONS

Option	
ASV	Scraping device
TR	Hopper

1.6 VERSION ADMINISTRATION

Document no.	1-980-001-BL
Document description	Operating manual
Document language	en
Document class	Original
Machine description	Elevator Tipper
Machine type	HK1200
Machine serial no.	see type plate

Document	Version	Date of change	Author
1-980-001-BL	V 8.3	2024-08-08	LN
1-980-001-BL	V	2024-08-08	LN

2 SAFETY

2.1 INTENDED USE OF THE MACHINE

The machine / plant is only intended to be used for food manufacture in the following industrial fields and research institutes:

- a. Food industry (incl. craft businesses)
- b. Technical / scientific universities
With the exception of radiological, biotechnical, purely toxic, military and pyrotechnical technological and scientific areas.

Applications in other commercial areas and in households or other private areas are to be excluded.

The machine / plant may only be used and maintained by the persons described in the chapter "User".

The machine / plant is especially intended for lifting and tilting of containers specified in the technical data.



NOTICE!

The elevator tipper may only be operated with the bowls provided.

The maximum transport weight must not be exceeded!

(See technical data)



NOTICE!

Another or further-reaching use is considered as improper.



NOTICE!

The intended use also means complying with the Operating Manual and the inspection and maintenance intervals are met.



2.2 REASONABLY FORESEEN MISUSE

The following types of misuse are foreseeable and are to be excluded by the user:

- Nonobservance of the Operating Manual
- Exceeding of the maximum permissible product quantity
 - Lifting of types of bowls deviating from the type plate of the lifting platform
 - Transport of persons

2.3 ATEX – ZONE CONCEPT



The machine delivered is a system of electrical and non-electrical devices and components that is **NOT** envisaged for use in or in conjunction with potentially explosive areas of the zone concept.

The conception of the machine was **NOT** executed corresponding to the safety requirements of the European guideline 2014/34/EU ("ATEX-Guideline").

The division of the zones took place inside and outside the plant without zoning!

2.4 EXTERNAL MACHINE- / PLANT COMPONENTS

If external machine/system components are used, which are not controlled by the machines/system control system but by an external control system, then the operator has to assure that no person stands on the stairway or the platform or in any other hazard area of the machine/system.

2.5 HAZARDOUS AREAS ON THE ELEVATOR TIPPER HK1200

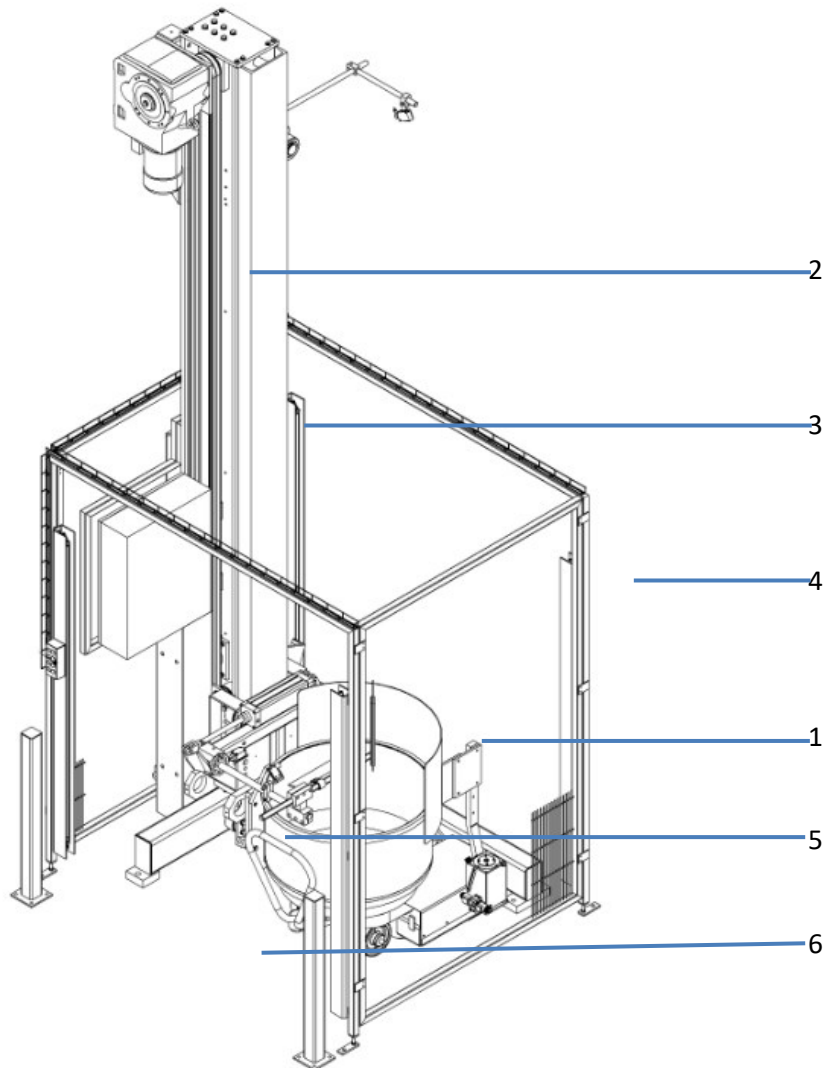

Figure 2-1 | Hazardous areas on the Elevator Tipper HK1200

	Hazard area	Danger
1	Movement area of the lifting platform Movement area of the scraper (optional)	Risk of crushing, impact
2	Disc, wheels and chains	Risk of crushing, tearing and cutting
3	Guide rails and drive mechanism	Risk of crushing and tearing
4	Zone of tipping mixture	Danger due to mixture falling
5	Zone of bowl drive / tong	Risk of crushing, shear and drawn in
6	Area under the raised bowl	Risk of crushing

i NOTE!

Elevators with safety cage
(2) and (3) partly within the guard
(1) only in the tilting area

**DANGER!**

Maintenance switch at the elevator.
Danger to life from falling bowl!
The "Maintenance" operating mode may only be used "without a bowl"
and should only be switched on for service purposes!

**CAUTION!**

(4) This hazard arises between a DIONSA machine and a machine from another manufacturer. Therefore, it is the operator's responsibility to evaluate this danger point and, if necessary, to initiate protective measures.

DANGER ZONE ON PNEUMATIC /HYDRAULIC SYSTEM**CAUTION!**

Pneumatic and hydraulic hoses are under pressure and can burst.
Risk of injury due to whipping hoses, compressed air or hydraulic oil.
The hoses should be regularly inspected visually, see maintenance plan.

2.6 WARNING SIGNS ON THE MACHINE

2.6.1 GENERAL WARNINGS



DANGER!

Danger of electric shock!

Risks due to electric voltage. Keep the switchgear and control cabinets closed. Disconnect from the mains before working on electrical equipment.



WARNING!

Entanglement hazard due to moving machine parts!

Danger of crushing or tearing limbs!

Keep clear of moving machinery parts.



WARNING!

Danger due to improper operation of the machine / plant!

These operating instructions must be read and understood prior to any work on the machine.

These operating instructions must be accessible at all times in a complete and legible condition. Observe the operating instructions!



NOTICE!

Breakdown caused by water jets or high-pressure cleaners!

Electrical components can be damaged or fail. Corrosion can occur inside the machine! Do not use water jets (hose) or high-pressure cleaners for cleaning!



2.6.2 WARNINGS ON THE ELEVATOR TIPPER

DANGER!

Danger of life-threatening injuries due to falling loads!

Do not step under the load, stay outside the danger area!

Do not place any obstacles in the lowering area, risk of tipping over!

Bowl types other than specified on the type plate and persons must not be transported.

Observe the maximum load capacity of the lifting platform.

Tragfähigkeit

600 kg

Geeignet für Bottiche der Maschinentypen:

WV 160

WARNING!

Danger due to falling out bowls!

Do not transport any bowls other than specified on the information sign and in the operating instructions!

NOTE!

The load capacity shown as an example refers to the elevator tipper HK(V)224.

Please find the actual load capacity in chapter „Technical Data“.

LOAD CAPACITY

HK600, HK1200	= 1200 kg
HK300	= 600 kg
HK(V) 224	= 600 kg
RK	= 200 kg

i NOTE!

The elevator tipper only works with closed, safety-based “Elevator tipper release” contact.

This contact may only be bypassed if the safety-relevant points have been checked and there are no safety concerns.

2.7 SAFETY DEVICES AT THE ELEVATOR TIPPER HK1200

2.7.1 PROTECTIVE DEVICES FOR OPERATOR PROTECTION

MAIN SWITCH / MAINS PLUG

Actuating the main switch, pulling out the mains plug, disconnects the machine from the power supply.

INTERRUPTION IN THE EVENT OF DANGER

Actuating the EMERGENCY STOP button interrupts the program sequence. After unlocking the EMERGENCY STOP button, the machine can be restarted.

ENCLOSING THE MOVEMENT AREA OF THE LIFTING PLATFORM

Safety cage gate

The safety cage gate has an emergency stop function. The machine stops the program sequence when lifting the safety cage gate. Once closed, the machine can be restarted.

Safety cage with light curtain (alternative to the safety cage gate)

The safety light curtain is a contactless protective device. The light curtain has an emergency stop function.

 DANGER!

Danger of protective device becoming ineffective

The effectiveness of the light curtain must be checked daily by a qualified person.

See chapter “Servicing and maintenance requirements”

PLS-Laserscanner (alternative to safety cage gate)

The PLS laser scanner is a non-contact protective device and has an emergency stop function.

A deflected laser beam scans the protected area for persons or objects.

The protective area is safeguarded by the PLS from a height of 300 mm above the floor.



DANGER!

Risk of ineffectiveness of the protective device

The effectiveness of the laser scanner must be checked **every two years** by a competent person.

See chapter "Maintenance and servicing instructions".

Safety bar (only in conjunction with a control device with automatic reset - dead man's control)

The safety bar has an emergency stop function.

The machine stops the lifting or lowering operation when lifting the safety bar.

Once closed, the machine can be restarted.



WARNING!

When lowering the lifting platform, the operator must make sure that nobody or no objects are in the movement area.

Substantial risk of injury due to tipping over of the elevator tipper.

BOWL RECEPTACLE

LIMIT SWITCH BOWL RECEPTACLE (HYDRAULIC TONG LOCK)

This limit switch checks the presence of a properly locked bowl.

The limit switch must switch before the end position of the bowl.



NOTE!

With the option bowl carriage with rod mount, a mechanical stop prevents the bowl carriage from falling out.

In this configuration, there is no bowl receptacle limit switch.

Limit switch tong lock closed

This limit switch checks the correct locking of the bowl.

DROP PROTECTION (ONLY HK (V) 224 AND HK1200)

The drop protection consists of a pivoted lever attached to the elevating carriage, which meshes with a toothed rack attached to the elevator tipper frame or with openings in the elevator tipper frame. In the case of a chain or transmission breakage, this stops the downward motion of the lifting platform.

PRESSURE MONITORING (ONLY WITH LIFTING PLATFORMS WITH HYDRAULIC TONG LOCKING)

The hydraulic closing pressure of the tong locking is monitored by a pressure switch. When reaching the lower pressure threshold, the hydraulic unit increases the pressure back up to the set maximum pressure.

This effectively prevents the unintentional opening of the interlock.

POWER MONITORING OF TONG LOCK CYLINDER (ONLY WITH LIFTING PLATFORMS WITH ELECTRIC TONG LOCKING)

The closing pressure of the electric tong locking is monitored by a current evaluation unit. When reaching the set current value, the drive is switched off.

SAFETY DEVICES AT THE ELEVATOR TIPPER HK1200

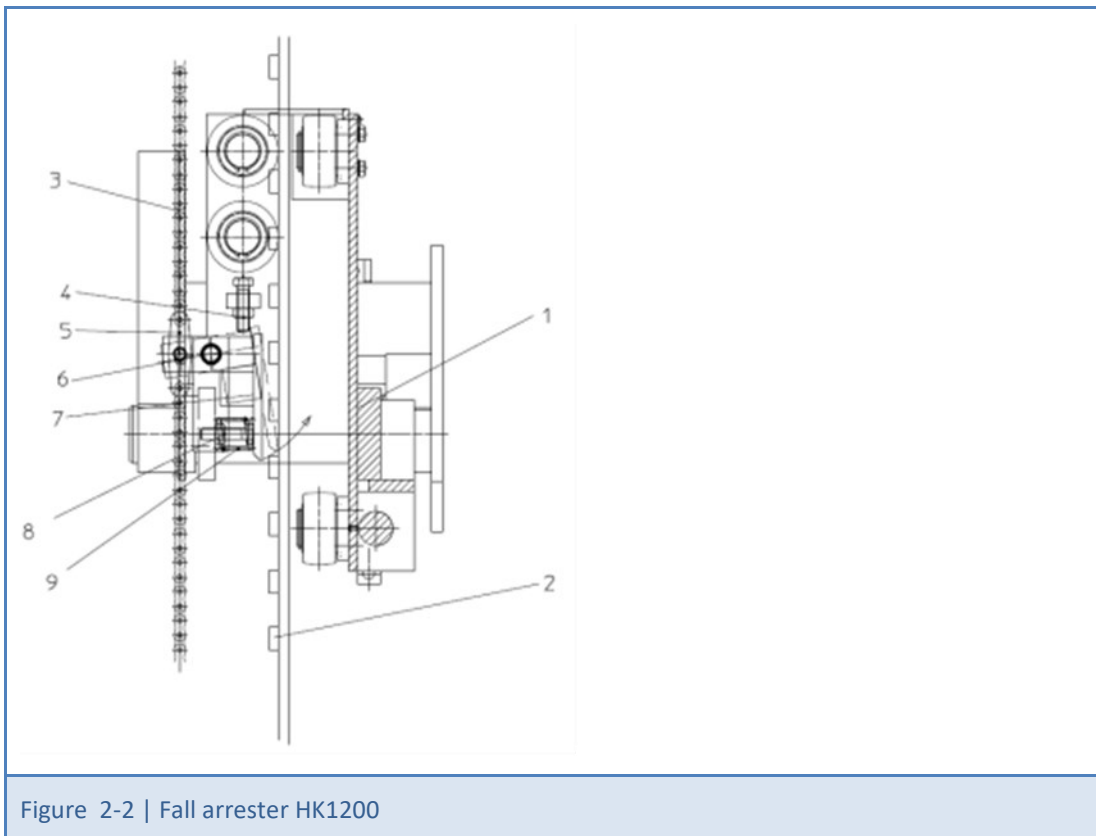

FALL ARRESTER HK1200

The DIOSNA-elevator HK1200 is equipped with fall arrester devices which, in the event of a chain break, protect the lifting carriage with lifting platforms and bowl against falling.

The drive chain (3) is coupled to the lifting carriage (1) by means of a chain connection (5).

In the event of a chain break (3), the fall arrester (7) is deflected outwards against the cams of the elevator column (2) by means of the spring action (9) and stops the lifting carriage from falling down.

In total there are two chain strings and two fall arrester devices.



NOTE!

The type of enclosure of the movement area of the lifting platform depends on the configuration:

- Safety bar (only in conjunction with a control device with automatic reset - dead man's control)
- Safety cage with mechanical gate (manually or power-operated)
- Safety cage with light curtain
- Protective device with laser scanner

You can find details of the configuration of your elevator tipper from the order confirmation.

LIMIT SWITCH CLAMP CLOSED

This limit switch monitors the clamp position "clamp closed"

(only for bowl type W240 and W401)

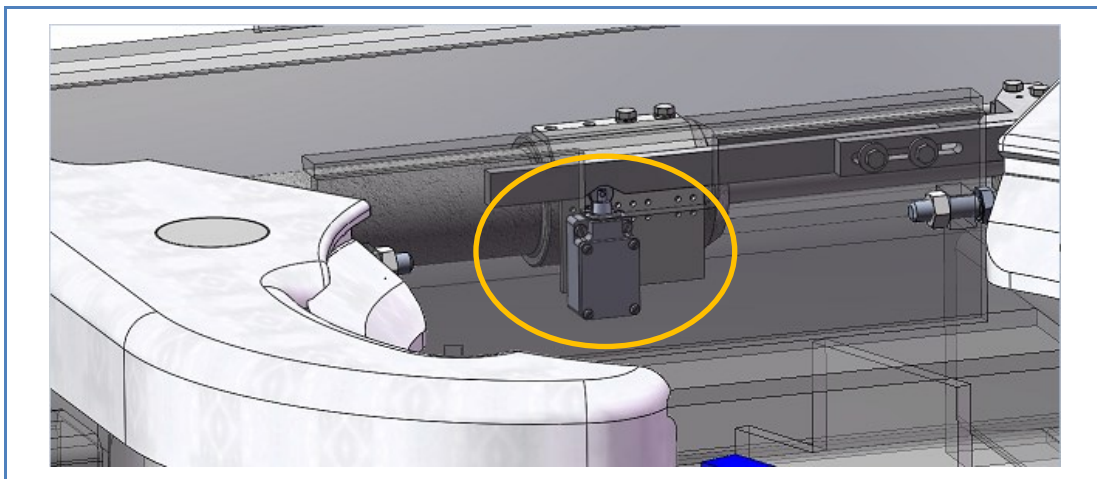

WHEEL TRAPS

The wheel traps prevent the bowl trolley from rolling back.

(only elevator tippers with a fork-platform (only cross-tilting) or rod-platform)

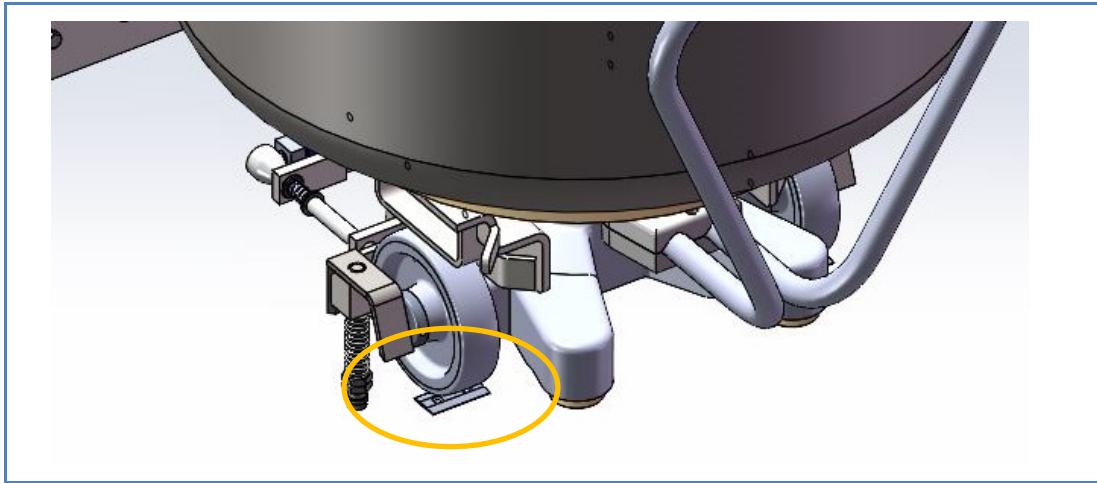

LIMIT SWITCH "BOWL INSERTED" CROSS-WISE TIPPER, WITHOUT TONG LOCK

These limit switches check the presence of a properly locked bowl. Each limit switch must switch before the end position of the bowl.

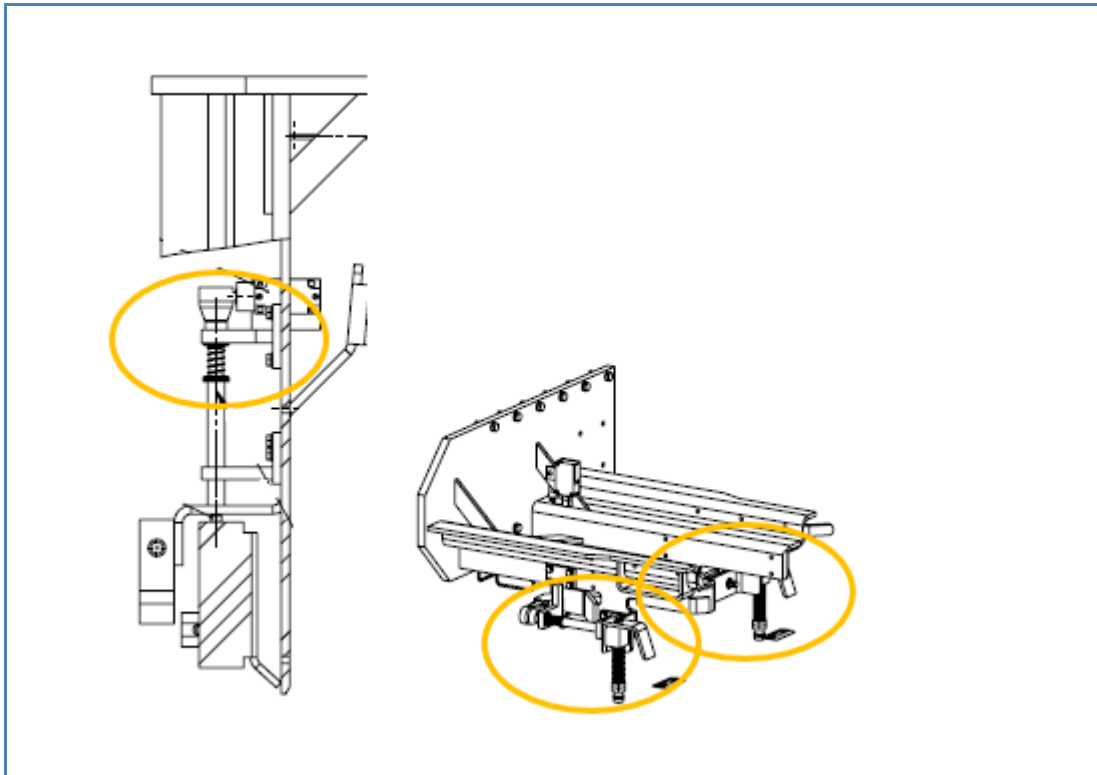

2.7.2 PROTECTIVE DEVICES FOR MACHINE PROTECTION

DRIVES

The motors are protected by overload relays/ motor protectors.

If they respond to overload or defective line power supply, the machine will be operable again after approx. 1 Minute.

The cause must be found and eliminated immediately.

2.7.2.1 PROTECTIVE DEVICES LIFTING TIPPER

UPPER HOIST LIMITING

When the end position of the tilting position has been reached, the elevator is switched off by a limit switch.

The pass over the end position is prevented by a mechanical end stop.

LOWER HOIST LIMITING

After reaching the lower end position, the elevator is switched off by a limit switch.

The pass over the end position is prevented by a mechanical end stop.

BOWL MOUNTING

This limit switch controls the presence of a properly locked bowl.

For plastic bowl, a light sensor is used for this purpose.

PRESSURE SWITCH HYDRAULICALLY (NOT FOR HK170)

The hydraulic closing pressure of the tong lock is monitored by a pressure switch. When the lower pressure threshold is reached, the pressure is increased again to the set maximum pressure via the hydraulic unit. This effectively prevents unintentional opening of the locking mechanism.

PRESSURE SWITCH ELECTRICALLY (NOT FOR HK170)

The electric current of the tong lock is monitored. When the lower threshold is reached, the drive motor stops.

2.8 RESPONSABILITY OF THE OPERATING COMPANY



DANGER!

Safety devices must not be removed or manipulated.

The proper functioning of the protective devices must be ensured by regular checks

Considerable danger of injury!

The machine must be switched off immediately if any defects are noted. It may only be taken back into use following rectification by a specialist.

The machine may only be used in technically faultless condition as intended, with the operator being aware of safety and possible hazards and observing the Operating manual. Malfunctions which may impair safety must be eliminated immediately! The machine must be shut down until the repair.

The operating company must take care that all protection devices, lockings and couplings are checked regarding their safe condition by an expert in regular intervals, at least once a year. The result of this check must be recorded in a test report (informal note with date and signature).

Modifications, additions and alterations may not be performed on the machine without DIOSNA's written permission! This specifically applies for the installation and setting of safety equipment and valves as well as for welding operations on supporting parts.

The operating company is responsible for the proper functioning of all safety devices, interlocks and couplings.

The user is responsible to make sure that the environment is in a condition that the operators can use the plant safely.



CAUTION!

The inspection and maintenance intervals must be observed.



NOTE!



On request, a sample test book is available at DIOSNA.

2.8.1 PERSONAL PROTECTIVE EQUIPMENT

The personal protective equipment serves to protect personnel against hazards that could affect their safety or health at work.

Personnel must wear personal protective equipment when carrying out the various tasks on and with the machine.

- The protective equipment to be worn for the respective work in accordance with the risk assessment must be used and put on before starting the respective work.
- Follow the instructions on personal protective equipment displayed in the work area.

Symbol	Description
	<p>Protective work clothing</p> <p>Protective work clothing is close-fitting work clothing with low tear resistance, tight sleeves and no protruding parts. It is primarily intended to protect against being caught by moving machine parts. Do not wear rings, chains or other jewellery.</p>
	<p>Safety shoes (DIOSNA recommends at least protection level S2)</p> <p>Safety shoes are used to protect against heavy falling parts and slipping on slippery surfaces.</p>

2.8.2 OPERATOR

The machine may only be used by persons instructed in DIOSNA applications or personnel additionally trained by DIOSNA. They must also have read and understood the Operating Instructions as well as all other instructions.



WARNING!

Children may not use the machine.

Youths may only use the machine under supervision.

Only trained specialists may carry out commissioning and all servicing and repair work. The same also applies to the removal of apparel for cleaning tasks. These must be clearly justified for carrying out work in the areas of mechanics, hydromechanics and electro technology. They must have read and understood the Operating manual and in particular, the chapter "Safety information".

All other work in the areas of transport, storage, operation and disposal may only be carried out by suitably trained persons who have understood the instructions.

Other employees of the operator who may be nearby (e.g., from other areas such as administration) must maintain a secure distance from the machine by way of the definition of traffic routes. These routes may only be departed from if supervised by instructed personnel of the operator.

The machine may not be accessible to the public. Access to a specialist audience is possible for demonstrations, trials, trade fairs and similar events. As far as the installation may be in operation for this purpose and no additional safety measures such as barriers enable direct access to the machine, the following requirements will apply:

- Minimum age, 16 years
- The machine may not be operated, therefore, no work carried out, i.e., the installation may only be used by the operator's trained personnel.
- Visitors must at all times be supervised by trained specialists and instructed in general safety rules.



NOTICE!

The operator's general safety measures (e.g., traffic routes, fire protection and if necessary, explosion protection) must be known and available to all users of the machine.

i NOTE!

Observe the applicable legal regulations of the country in which the machine is operated when young people are employed.

2.8.3 OVERVIEW OF USER GROUPS

USER GROUPS

Personal	Qualification
Operator	Appropriate instruction in the areas of: <ul style="list-style-type: none"> • Functional sequences of the machine • Operations
	Knowledge in the following areas: <ul style="list-style-type: none"> • Competencies and responsibilities in the activity • Behavior in case of malfunction
Maintenance personnel	Sound knowledge in the following areas: <ul style="list-style-type: none"> • Mechanical engineering • Electrical engineering • Pneumatics • Hydraulics
	Authorization for the activities (according to the standards of the safety technology of the country where the machine is operated): <ul style="list-style-type: none"> • Commissioning of devices • Grounding devices • Labeling devices
	Sound knowledge of the design and operation of the machine.

REQUIRED QUALIFICATION OF THE MAINTENANCE PERSONELL

Action	Qualification
Work on mechanical equipment	Industrial mechanic or Instruction, the work may only be carried out under the guidance and supervision of an industrial mechanic according to the recognized rules of technology.

Work on pneumatic equipment	Special knowledge and experience in handling pneumatics.
Work on hydraulic equipment	Special knowledge and experience in handling hydraulics.
Work on electrical equipment	Electrical engineer or Instruction, the work may be carried out under the supervision and supervision of a qualified electrician according to the electrotechnical rules.

2.8.4 INSTRUCTION AND TRAINING SUPPORT

As the company owner/operator, you are obliged to inform and instruct the operators on the existing legal and accident prevention regulations and on the safety devices available for the isolator. This duty also covers safety devices which are installed in the vicinity of the isolator. Here, the different expert qualifications of the staff members must be taken into account.

Operating personnel must understand the instructions and the observance of the instructions must be ensured.

This is the only way to achieve a safety- and risk-conscious working attitude of your personnel. Compliance with the instructions should be checked at regular intervals. Therefore, as the company owner/operator, you should have each staff member confirm in writing their participation in the training.

On the following pages, you will find examples of training topics and a master copy form for a confirmation certifying attendance in the training / instruction.

2.8.5 EXAMPLES OF TRAINING TOPICS

General Safety
<ul style="list-style-type: none"> • Accident prevention regulations • General legal regulations • General safety regulations • Measures in cases of emergency • Special aspects upon contact with chemical substances (in the pharmaceutical industry) • Safety devices in the periphery of the machine / system •

Operating of the machine / system
<ul style="list-style-type: none"> • Safety information for the operation of the machine / system • Handling the safety devices of the machine / system • Meaning of symbols and signs • Handling the operating elements of the machine / system • Explanation of the Operating and Maintenance Instructions for operating staff • Specific experience of the operator in handling the machine / system • Elimination of operational disturbances • Daily cleaning • ...

Maintenance and servicing instructions
<ul style="list-style-type: none"> • Specific safety regulations for maintenance and servicing • Handling of cleaning agents and lubricants according to regulations • Specific experience of the operator in the fields of maintenance, servicing and cleaning of the machine / system • ...

2.8.6 EXAMPLE OF AN INSTRUCTION CERTIFICATE

CONFIRMATION OF THE INSTRUCTIONAL <input type="checkbox"/> RESP. TRAINING COURSE <input type="checkbox"/>		
Topic:		
Date:	Instructor:	Instructor's signature:

No.	Surname, First name	Signature
1		
2		
3		
4		
...		

3 MACHINE OVERVIEW

3.1 TECHNICAL SPECIFICATION DIOSNA ELEVATOR TIPPER HK1200

3.1.1 FRAME

Stationary execution with feet, floor clearance. Frame as vertical column made from wide I-beam

For installation on floor, fixing with anchor bolts

Right – or left – handed execution.

i NOTE!

Please refer to the order confirmation for details.

LIFTING PLATFORM

Lifting platform, bowl locking by means of clamps, for the collection of the Diosna-bowls (see technical data)

ALTERNATIVE

with bowl extension

i NOTE!

Optional equipment

BOWL DRIVE

Bowl drive by friction wheel (or optional toothed wheel) and geared motor, motor protection by overload relay.

HYDRAULIC DRIVE

Hydraulic drive by hydraulic unit.

The temperature of the hydraulic system is monitored.

SCRAPING DEVICE

Pneumatically movable scraping device, scraping edge made from Polyethylene mounted on elevator framing.

ALTERNATIVE

Mounted on lifting platform

ALTERNATIVE
without scraping device

i NOTE!

Optional equipment

3.1.2 FALL ARRESTER

With fall arrester of lifting platform through bolt and shaft

LIFTING OF PLATFORM

Lifting action by roller chain(s) driven by transmission brake motor, motor protection by overload relay.

3.1.3 LIFTING CARRIAGE

Lifting carriage movable within the frame, with adjustable wheels made from cast polyamide, execution with friction bearing. Joint plate made from steel, maintenance-free execution with plastic friction bearing and mounting plate for lifting platform.

POSITIONING CONTROL PLATFORM

Final positions of lifting platform secured by limit switch

3.1.4 SAFETY CAGE

Safety cage with gate, made from stainless steel, to be lifted and lowered manually, electrically secured.

ALTERNATIVE
motorized gate

ALTERNATIVE
Safety bow

i NOTE!

Protective bar only in conjunction with a dead man's control.

SAFETY EQUIPMENT

The Elevator Tipper has to be prepared that an unintended opening of the clamps is not possible. Execution of safety equipment accordingly to category 3.

3.1.5 ELECTRIC SWITCH AND CONTROL UNIT

Electric switch and control unit built into a box.
Operation by push buttons.

LIGHT SENSOR

Light sensor for monitoring the filling level in the downstream dough container.

i NOTE!

Optional equipment

CONTROL PROCEDURES WITH LIGHT SWITCH

Automatic control procedures via light switch signal for lifting, tilting, scraping and lowering
The elevator only starts when the contact "Release elevator" is available.

3.1.6 CONTACT EXCHANGE TO EXTERNAL CONTROLS

All contacts as potential-free contacts

- External control -> DIOSNA
Safety-related contact "Release elevator"
- DIOSNA -> External control
"Elevator is running"

The contacts are provided with a bridge when the elevator is delivered. If necessary, the bridges can be removed.

i NOTE!

Optional equipment

AIR SUPPLY

Maintenance unit with main pneumatic valve for pressureless switching of the pneumatic components, pressure switch for monitoring 'Compressed air available'.

The air supply is installed according to the drawing.

i NOTE!

Only for lifting platforms with scraping device

3.2 TECHNICAL DATA DIOSNA ELEVATOR TIPPER HK1200

i NOTE!

The technical specification, performance data and dimensions can deviate order related.

Decisive in case of doubt is the order confirmation.

3.2.1 LIFTING LOADS AND DESIGN DATA

Type		HK 170	HK(V) 224	HK 300	HK 600	HK 1000	HK 1200
max. load	[kg]	600	600	600	1200	2000	1200
max. tilting	N/h	6	10	16	16	16	16
Operating time	h/d	8	8	24	24	24	24

3.2.2 PERFORMANCE DATA

Lifting drive *		HK 1200
Design	[kg]	H4
Power	[kW]	2,4 / 3,2
Speed (50 Hz)	[1/min]	7,1 / 14,2

**) All motors insofar as technically possible energy efficiency class IE2*

Weight		HK 1200
approx. weight	[kg]	according to order specification **)

***) The weight depends on the tipping height and the execution*

Noise emission		HK 1200
Noise pressure level	[db (A)]	70

fuse		HK 1200
230 V		25
		4x4
400 V	[A]***	16
	[mm ² Cu]	4x2,5

***) slow

3.3 PERMITTED AMBIENT CONDITIONS

	Range
Admissible ambient temperature	50 °F < T _a < 104 °F (10 °C < T _a < 40 °C)
Admissible ambient temperature of cleaning agents	50 °F < T _{WIP} < 140 °F (10 °C < T _{WIP} < 60 °C) 176 °F (80 °C) with on-site personal protective equipment.
Admissible atmospheric humidity	25 ... 75 % rel. atmospheric humidity

3.4 DIMENSIONS ELEVATOR TIPPER MACH.-SER. -NO. SEE TYPE PLATE

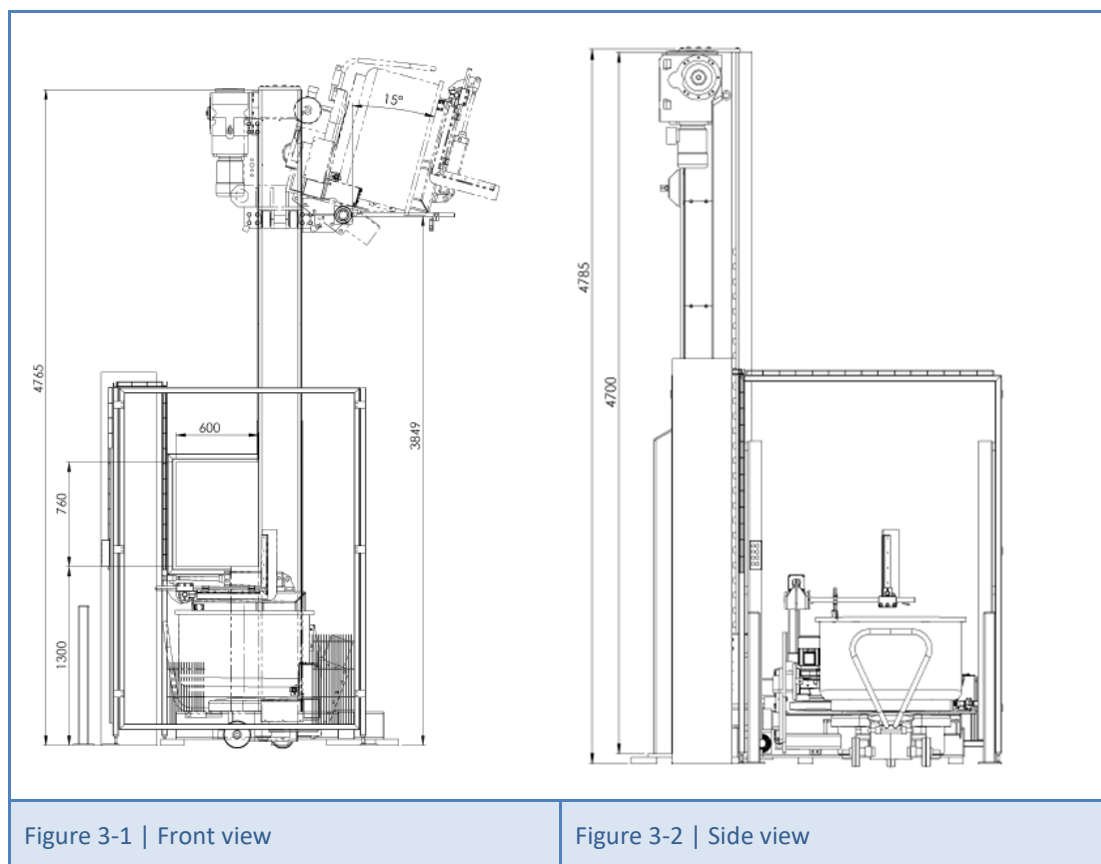

Figure 3-1 | Front view

Figure 3-2 | Side view

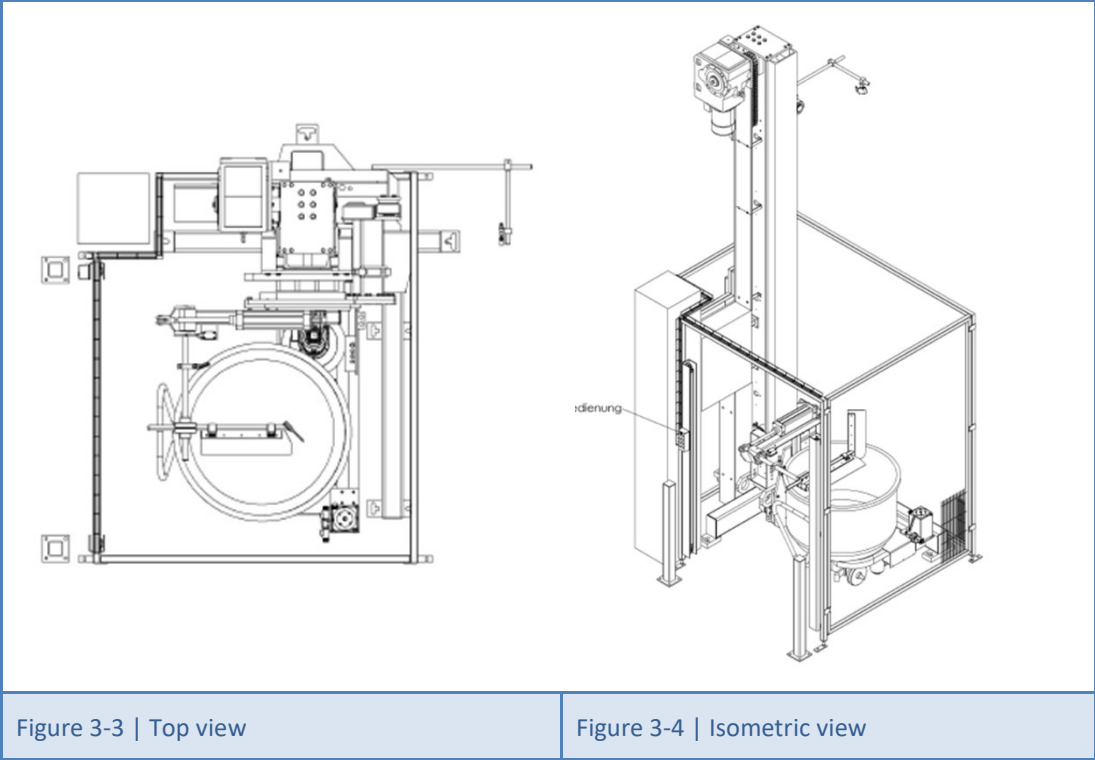

Figure 3-3 | Top view

Figure 3-4 | Isometric view

4 TRANSPORT AND SETTING UP

4.1 UNLOADING AND TRANSPORT

The machine or the individual parts of the system are shipped partially disassembled. The packaging is based on the agreed shipping method (truck, container or wooden crate).

All packages should be unloaded using a suitable lifting tool - a mobile crane or forklift with sufficient load capacity is recommended.

Depending on the type of packaging, this can be provided with pictograms:

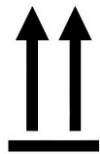

This way up



Fragile, Handle with care



Keep dry



Balance point



Sling here

Follow the instructions.

Transport the machine with suitable, the weight of the machine corresponding transport elements (e.g. Heavy-duty rolls) to the intended location. The rollers can be placed under the machine by means of lifting trucks with sufficient load capacity. The rollers must be sufficiently secured against slipping.

Unload and transport all packages with an appropriate device – advisably a mobile crane or lift truck.

4.1.1 TRANSPORT OF THE ELEVATOR HK1200

The machine is equipped with receptacles for attaching the hoists.

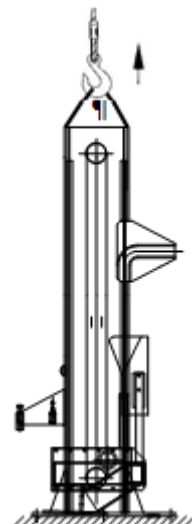

Figure 4-1 | Hoist receptables HK1200



NOTICE!

The elevator HK1200 must be transported with a pallet truck only horizontally.



WARNING!

Observe the lifting capacity of the hoists! (see technical data section for the weight of the machines)

Risk of serious injuries due to falling loads!

Do not step under a lifted load!



WARNING!

Ensure that the machine does not tip during transport.

Risk of squeezing, knocking and cutting!

Danger due to falling loads! Use transport and assembly safeguarding.



NOTICE!

Follow general accident prevention regulations and legal regulations on installation site as well as the instructions from the chapter 'safety'!

The operating company is responsible for the safe unloading, transport and installation of the machine!



NOTICE!

Protect the lifting gear from sharp edges!

4.2 SETTING UP

4.2.1 GENERAL INFORMATION

Place the machine or individual parts of the plant on a stable, and sufficiently loadable floor.

After alignment and connection of the machine, all covering plates are remounted.



WARNING!

During the erection of the machine, or plant components, make sure that crushing and shearing is avoided.

Provide for sufficient safety distances between moving parts or between moving parts and stationary parts (adjacent machines, ladders, platforms, catwalks, etc.).

Please find the reference values for safety distances in the standards EN 12100 und EN 13857 (as amended from time to time).



DANGER:

Place the switch cabinet in close vicinity (2 m) to the machine, so that the hazard area can be overseen by operators.

Otherwise, an additional EMERGENCY STOP switch on the machine is required.



WARNING!

On machines that are equipped with a plug the socket must be visible by the operator.



NOTICE!

Install the machine in a way that it is also possible to clean the surrounding area.

(Required space: see chapter on "Dimensions")

The plant components are anchored using heavy-duty fittings.

If the floor is not completely level, the machine has to be levelled at the points of attachment with corrosion-resistant sheets or flat iron.

The floor must conform over the entire minimum thickness to at least concrete strength class C20/25 according to DIN 1992 in hardened condition.

4.2.2 ATTACHMENT WITH HEAVY-DUTY ANCHORS

Install the plant component in the place of installation. Drill the holes through the attachment drill holes in the base plate using a suitable drilling machine. Fix with dowels.

Please find detailed information in www.hilti.com

4.2.3 ATTACHMENT WITH HILTI HVU SYSTEM (CHEMICAL DOWELS)

The machine is to be set up at the intended location. Drill the holes through the attachment drill holes in the base plate using a suitable drilling machine. Place chemical dowel in the drilled hole. Blow out drilled hole beforehand. Attach with anchor rod.

		HVU- M12x110	HVU – M16x125	HVU – M16x190	HVU – M20x170	HVU – M20x255
Diameter of attachment drilled holes:	[mm]	16	20	20	25	25
Minimum floor thickness	[mm]	160	170	260	240	350
Drilled hole diameter:	[mm]	14	18	18	24	24
Drilled hole depth:	[mm]	110	125	190	170	255

Please find detailed information in www.hilti.com

Sufficient hardening time according to the manufacturer's information must be observed when using chemical dowels. Processing temperature -5°C - +40°C

After attachment, the base plate must be sealed to prevent liquids penetrating the drilled holes underneath the base plate; hygiene risk

Ensure equivalent load-bearing capacity if attachment systems from alternative manufacturers are used.

4.2.4 MOUNTING WHEEL-TRAPS ON ELEVATOR TIPPER WITH FORK – OR ROD PLATFORM

For elevator tippers with a fork-platform (only cross-tilting), or rod-platform, the wheel traps must be installed so that the bowl trolley is securely locked.



CAUTION!

Risk of crushing and catching by machine parts!

The bowl trolley can roll back out of the lifting platform.

Install the wheel traps (1) with fastening material to prevent the bowl trolley from rolling back and to ensure the secure locking.

The installation of the wheel traps must be documented by the responsible personnel.

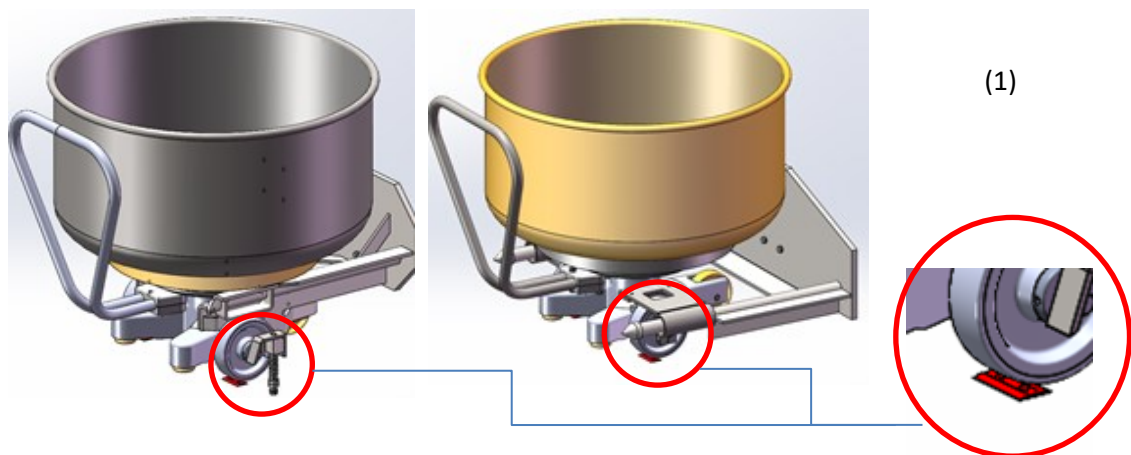

Fig. 4-2: Mounting wheel traps

4.3 CONNECTING

Connect all tubes and electrical connections accordingly to the delivered drawings and diagrams.

Please refer to the chapter for technical data for the ratings of the fuses to be installed by the customer.

The permanent connection must only be installed by a qualified electrician in conformity with EN 60204, DIN VDE 0100, or equivalent connecting conditions.



CAUTION!

To avoid static charge, ground all parts of the machine by appropriate measures.

Securely ground non-conductive hoses as well.



After installation, an initial test according to EN 60204-1 must be carried out.

In particular, all machine parts must be checked for safe earthing and an insulation measurement must be carried out!



NOTICE!

The operation voltage is specified on the machine's type plate.

This operation voltage must match the three-phase supply network at site.

5 SETTING INTO OPERATION

5.1 BEFORE SETTING INTO OPERATION

Before commissioning, all plant components must be erected and installed in compliance with the plans delivered.

DIOSNA recommends commissioning only with the assistance of the DIOSNA specialist staff.

5.2 SETTING INTO OPERATION

5.2.1 FUNCTIONAL TEST

- **CHECKING THE MACHINE**
No objects should be present on the machine and in the interior of the bowl
In particular all tools must be removed.
- **TEST RUN**
Operation see chapter "Control" or separate "Control Description"
All functions must be checked during the test run of the machine, in particular the correct rotating direction of the motors.
If the rotating direction is incorrect swap two phases of the power supply by a qualified electrician (clockwise rotation).
- **FUNCTIONAL CHECK OF THE PROTECTIVE DEVICES**
All protection devices must be tested for proper functioning
- **FUNCTIONAL CHECK OF THE CONTROL**
Operation see chapter "Control" or separate "Control Description"
- **FUNCTION CHECK OF THE LIMIT SWITCHES**
 - 1 When inserting the bowl, both limit switches must be switched before the end position is reached.
 - 2 When starting the elevator tipper without a bowl, the platform must not be raised.

5.2.2 SAFETY CHECKS

- **CHECKING THE OPERATING AREA OF THE LIFTING PLATFORM**
Insert the bowl and lift to the end position
The lifting platform, the bowl extension (if present) and the bowl must not touch adjacent parts.

The safety distances must comply with the legal requirements.
On-site stairs or work platforms must not cause any danger points.

i NOTE!

The operator is responsible for compliance with the legal regulations at the installation site.

- **UPPER HOIST LIMITING**
The lifting or tilting movement must be stopped by the limit switch before the mechanical end stop is reached.
- **LOWER HOIST LIMITING**
The lowering movement must be stopped by the limit switch before the mechanical end stop is reached.
- **BOWL RECEPTABLE**
The limit switch must switch before reaching the end position.

i NOTE!

With the option of bowl with rod holder, the bowl is protected against falling out by means of a mechanical stop.

This version lacks the limit switch bowl receptacle.

- **SAFETY GATE WITH LIGHT GRID, SAFETY DEVICE WITH LASER SCANNER**
The lifting or lowering movement must be interrupted immediately when the safety device is actuated.

5.2.3 EMERGENCY STOP BUTTON

All movements of the machine must stop immediately after pressing the emergency stop button.

5.2.4 START UP LIGHT CURTAIN

Commissioning of the light curtain must be carried out and documented by a person certified by SICK / KEYENCE.

5.2.5 STARTUP OF THE LASER SCANNER

Commissioning of the laser scanner must be performed and documented by a person certified by SICK.

5.2.6 CONNECTION CONDITIONS FOR THE SAFETY-RELATED CONTACT "ENABLE ELEVATOR"

The elevator only runs with closed safety-related contact "Enable Elevator".



DANGER!

Danger by an unsafe machine!

The contact may only be bridged if all safety-related points have been tested and there are no doubts on any safety function.

Written confirmation by specialist.

The bridge for the safety contact "Enable Elevator" is removed and delivered loosely in a bag in the control cabinet.

After assembling the elevator at the customer site, a safety matrix has to be filled out and signed (see electrical circuit diagram).

On the basis of this assessment, the bridge can be used for the safety-related contact "Enable Elevator" or the safety can be implemented by means of an external safety device.

5.3 RESTART AFTER STOPPING

If the machine is re-commissioned after power failure or a longer downtime, the following instructions are to be observed:

- Turn on the main switch
- Wait for error messages on the display of the control.
- If no error messages appear, the machine can be put into operation again.

6 OPERATION

6.1 DESCRIPTION OF THE MACHINE / SYSTEM'S FUNCTIONS ELEVATOR TIPPER HK1200

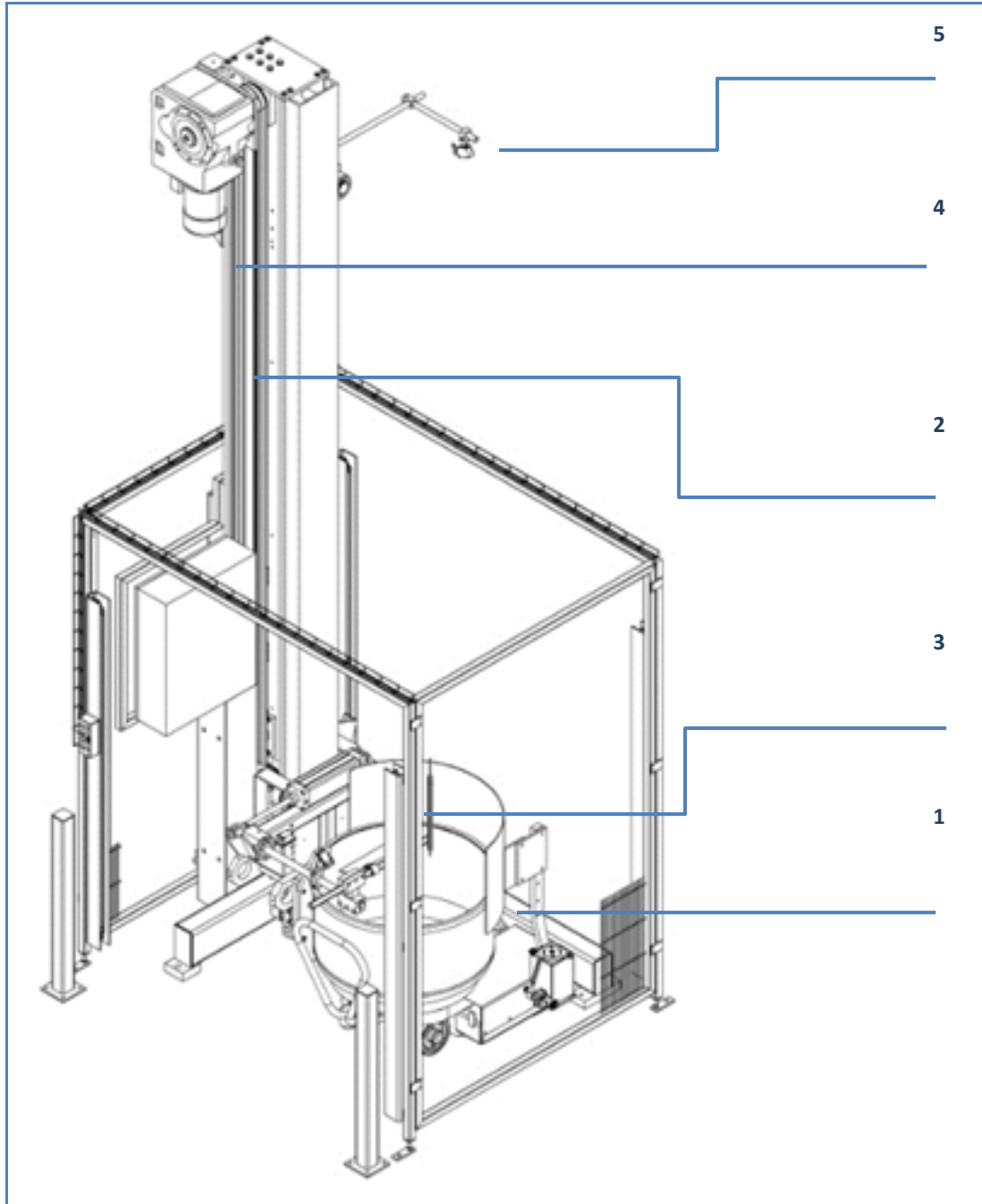

Figure 6-1 | Funktional principle of the elevator tipper (Example partly with special equipment)

No.	Component	Function
1	Lifting platform	
2	Guide rails / tracks	

3	Bowl	<p>The lifting platform (1) is pulled upwards by means of roller chains (4) via guide rails or tracks (2) with the locked bowl (3) and is tilted in the upper end position.</p> <p>The operating range of the lifting platform is secured by means of a safety cage or a safety bow (only in conjunction with a command device with self-acting reset - dead man control, outside the scope of Directive 2006/42/EC).</p> <p>The dough is emptied into the hopper below.</p>
4	Roller chains	The roller chains (4) are driven by an electric motor.
5	Scraping device	An optional scraping device scrapes out the bowl in the tipped position.
6	Control	The control elements are installed in the control cabinet.

6.2 DRIVING THE BOWL TROLLEY INTO THE ELEVATOR TIPPER

Before starting the lifting process, make sure that the bowl trolley is in the correct position. If wheel traps are installed, the wheel must be behind this trap to ensure that the bowl is locked.

A FORK-PLATFORM , CROSS-TILTING WITH AUTOMATIC LOCKING

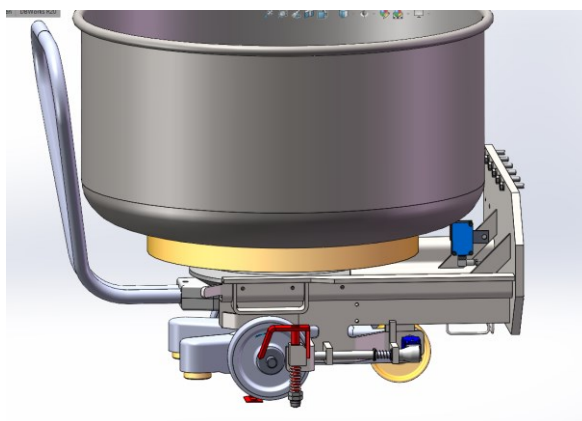

Position when retracting: the locking lever is raised via a spring mechanism. The bowl can be retracted. The position of the bowl is fixed via the wheel traps, the limit switch actuation must switch safely.

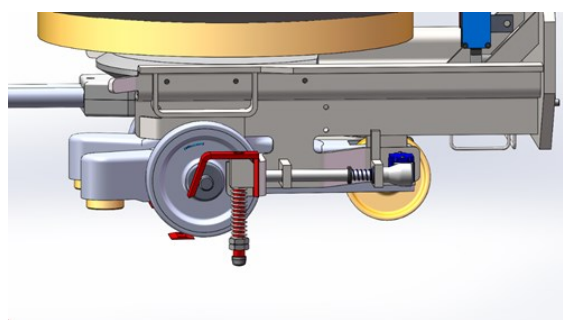

When it is raised, the locking lever lowers and the bowl trolley is fixed in the lifting platform via the axles using the locking lever.

ROD-PLATFORM:

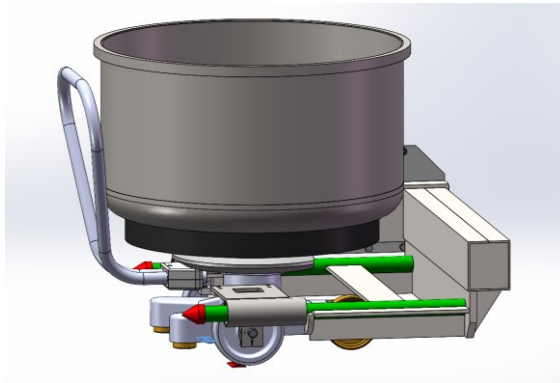

The bowl is held on the rods of the lifting platform via holding tubes. The position of the bowl is fixed via the wheel traps, the limit switch actuation must switch safely.

6.3 PUSH-BUTTON CONTROL WITH ITIMERN (EXECUTION D)

6.3.1 DESIGN OF THE CONTROL

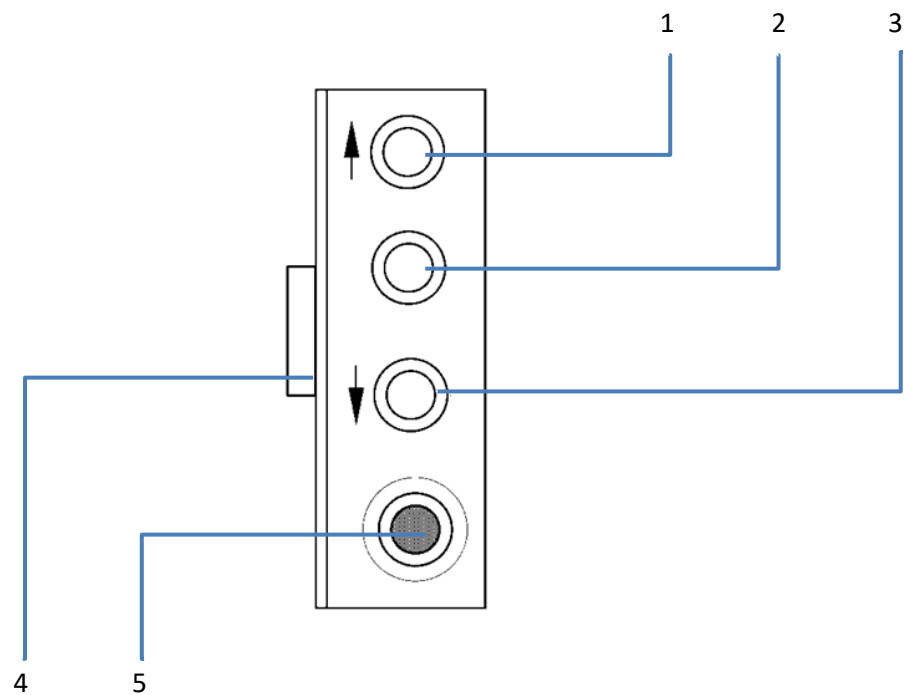

Figure 6-2 | Push button controlHK1200

Pos.	Function	Pos.	Function	Pos.	Function
1	Push button "Lift"	2	Push button "Stop"	3	Push button "Lower"
4	Main-Switch	5	EMERGENCY-OFF button		

6.3.2 OPERATING OF THE CONTROL

PUSH BUTTON "LIFT"

Pressing this button lifts and tilts the lifting platform.
The elevator only operates as long as the button is pressed (Dead man control).

PUSH BUTTON "STOP"

Pressing this button will stop the elevator immediately.

PUSH BUTTON "LOWER"

Pressing this button lowers the lifting platform.
The elevator only operates as long as the button is pressed (Dead man control).

EMERGENCY-STOP BUTTON

Pressing the [EMERGENCY STOP] button or opening the safety device will shut down the running machine. The machine can be put into operation again after the [EMERGENCY STOP] button has been reset and the safety device has been closed.

MAIN-SWITCH

The machine is switched on and off.

i NOTE!

Please refer to the 'Control Description' for the operation of the control unit.

6.4 SECURITY CHECK

i NOTE!

The functionality of the protective devices must be checked regularly. For further information see the maintenance chapter "Safety checks".

6.5 CUT OFF IN AN EMERGENCY SITUATION

In an emergency situation, press the EMERGENCY STOP button to stop the machine immediately.

The machine can only be restarted if the EMERGENCY STOP button is unlocked and, if present, the gate was closed.



DANGER!

The reason for the emergency stop must be investigated and corrected by a qualified electrician before the machine can be restarted.

Risk of ineffectiveness of protective devices.

Serious risk of injury!

7 CLEANING

7.1 GENERAL ASPECTS OF HYGIENE RISK

A machine does not primarily cause a hygienic risk. Only a certain product in connection with the machine can cause a hygiene risk. Only food processing causes a hygiene risk. Food include products that are more or less sensible. Therefore, it seems to be purposeful to select the product as parameter for the basic risk.

The hygienic sensitivity is decisive for the height of the risk in this decision-making level. The hygienic sensitivity is higher the higher the perishability of the product is and/or the ability to support pathogenic germs.

Source citation: Handbuch Maschinensicherheit, issue 1/96, BGN, ISBN-No. 3-920506-51-0

The DIOSNA machines are designed and constructed in compliance with the currently applying EC directives for food machines (particularly EN 1672-2 and ISO 14159). All product-contacted components are made of stainless steel or of plastic materials that are suitable for food contact.

To maintain the perfect hygiene standards and with this, to reduce the hygiene risk for the product, the machine must be cleaned regularly. The user has to specify the intervals and the required works for cleaning depending on the sensitivity of the product to be processed, e.g. within the frame of a HACCP concept.

A 'Risk graph' for the hygiene risk is helpful for specifying the necessary cleaning measures.

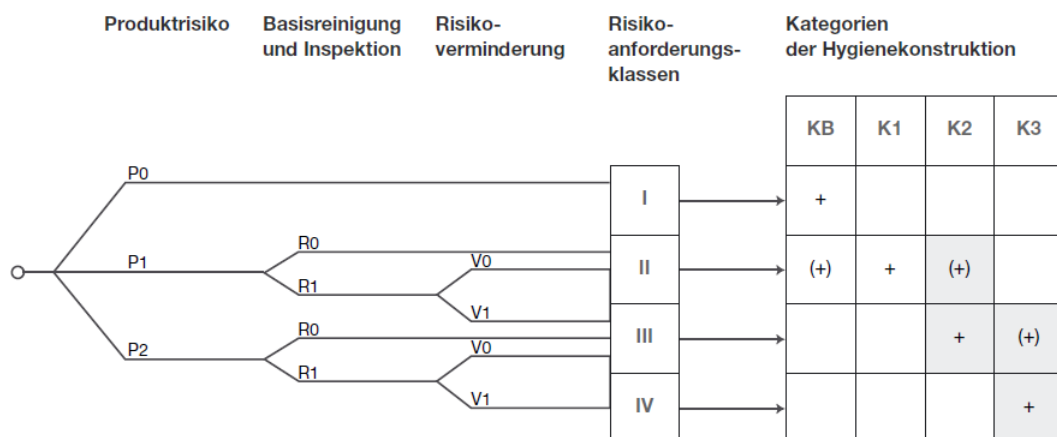

Legend	
P	Product risk
R	Basic cleaning and inspection
V	Risk reduction
K	Categories of hygiene design
+	Purposeful category
(+)	Possibly purposeful category

Note: Please find further information in the above mentioned 'Handbuch Maschinensicherheit'.

Cleaning of the product-contacted areas of the machines is seen to be the basic measure for reducing the product risk. After each cleaning process, check the result and repeat the process, if necessary.

However, depending on the product sensitivity, additional measures can be required, e.g. treating of the machine with a procedure that kills microorganisms. In the individual case, these methods must be coordinated with DIOSNA.

 **CAUTION!**

If not cleaned or only insufficiently cleaned, this will pose a high hygiene risk.

7.2 CLEANING OF THE MACHINE

 **CAUTION!**

During cleaning works secure the machine against accidental restart.
Drawing-in and crushing hazard
The machine may not be operated without a cover.

 **WARNING!**

Do not climb on machinery during cleaning
Danger of falling!
Use suitable working platforms

 **DANGER!**

Respect the security advices of the chapter "Service and maintenance instructions"!

They are cleaned with a damp cloth and a cleaner, described in the chapter "Cleaning agents". Product-contacted surfaces can be cleaned additionally with hot water and a brush depending on the degree of pollution.

The housing surfaces of stainless steel can also be cleaned with a water hose or a water shower and low pressure.

Product-contacted surfaces, e.g. kneading tools, wipers or coverings must be cleaned manually with hot water and auxiliary aids (brush).



NOTICE!

Remove adhering product residues from the bowl edge, also during production. Especially dried product residues cause increased wearing of the cover edge.

After cleaning with water, dry the machine to reduce the risk of corrosion. This particularly applies prior to longer downtimes.

WHEEL TRAPS FOR THE BOWLS (OPTION)

The wheel traps of the bowls are regularly inspected for dropping doughs or raw material residues and cleaned if necessary. Contaminated traps can cause the bowl to roll out of the platform.



NOTICE!

Sticking product residues cause damage to the machine!

- Cleaning has to be done at the end of the production process at the latest to avoid hardening of remaining residues.
- If the machine is not cleaned shortly after the end of production, the residues left after production can cause damage to the machine for which the manufacturer cannot be held responsible!



NOTICE!

Do not use hard objects, e.g. metal scraper, for cleaning purposes.

Metal scrapers damage the surface and with this, increase the hygiene risk because microorganisms can settle in the grooves.

Especially, Teflon® - coatings are damaged irreparably in this way.

If these are machines with clamp lock, apply grease on the slipping surfaces of the clamps that has been approved for food machines and meets the requirements specified in chapter "Lubricants".



NOTICE!

If it is operated without a grease film, wearing will be higher.

7.3 MACHINE AREAS THAT ARE DIFFICULT TO ACCESS

Due to design necessities, some positions exist that need increased cleaning attention and therefore, they cannot be integrated in the daily cleaning process.

Only a **SPECIALIST** is allowed to remove the covering plates (see chapter "User"). Please find the instructions for removing the covering plates in the spare part drawings that come with the machine.

7.4 CLEANING AGENTS

CAUTION!

The operators must wear their normal protective equipment or, if instructed by the manufacturer of the cleaning agent, they must wear additional protective equipment.



The components contacted by the cleaning agents (hoses, seals, and plastic materials) are resistant to the temperatures for which they are designed (max. 50°C) as well to the cleaning media and means recommended. As cleaning agent, a slightly alkaline cleaner (pH 12-13) can be used in a concentration of maximum 2.5% at a max. water temperature of 50°C. This mainly refers to the cleaning processes usual in the food industry with sufficient rinsing with mains water and/or purified water (VE).

Only products and raw materials may be used for the cleaning that have material properties, which are compatible with the substances of the machine (see "Materials of product-contacted parts")

NOTICE!

Highly concentrated (> 2.5 %) alkaline and acidic cleaning agents may not be used.

**NOTICE!**

Observe the instructions in the manufacturer's supplementary sheet!

**NOTICE!**

The machines must not be cleaned with water jets.

Higher pressure can cause damage to the electrical components and bearings.

They are allowed to be cleaned with water hose up to a maximum pressure of 10 bar and a temperature of up to 50°C.

Especially in the area of the electrical controls, water for cleaning purposes is only allowed to be used with extreme caution.

**NOTICE!**

Cleaning with hot steam is not allowed!

On request, DIOSNA machines can be designed for optional cleaning concepts, e.g. CIP cleaning or a procedure that kills microorganisms.

**NOTICE!**

Foam cleaning is not allowed!

On request, DIOSNA machines can be designed for optional cleaning concepts, e.g. CIP cleaning or a procedure that kill microorganisms.

8 SERVICING AND MAINTENANCE INSTRUCTIONS

8.1 GENERAL INFORMATION

The life cycle of the machine is not subject to certain limits, provided the use is authorized, regular maintenance is carried out according to this manual and fault causes are removed immediately.



WARNING!

Only use original DIOSNA spare parts or spare parts approved by DIOSNA!

We recommend obtaining an offer for a maintenance contract from DIOSNA.

Remove dust deposits, material deposits and fluid accumulation within and outside the machine. Only use products and substances with material properties that are compatible with the materials of the machine.



WARNING!

Contamination, detached components, imbalances or existing damage (e.g. bearing damage) can lead to a functional impairment or the destruction of components.

We recommend that all machine components be checked regularly for such impairments and that any impairments be rectified immediately.

Insufficient testing and maintenance can lead to not inconsiderable functional impairments up to the failure of components or functions.

The tests and periods we have mentioned are recommendations. Depending on the use of the machine and the resulting wear and tear, the periods can be extended, or the periods must be shortened. The decision about this is the responsibility of the operator. If you have any questions about changing the cleaning or maintenance intervals or extending the tests, DIOSNA will be happy to advise you at any time."

8.2 SAFETY INSTRUCTIONS



DANGER!

The safety checks must be performed regularly
(See chapter "Safety check")



DANGER!

Safety devices must not be removed or manipulated.
The proper functioning of the protective devices must be ensured by regular checks
Considerable danger of injury!
The machine must be switched off immediately if any defects are noted. It may only be taken back into use following rectification by a specialist.



WARNING!

All maintenance work on the machine may only be performed with the main switch turned off and secured or with the mains plug disconnected.
Danger of electric shock due to electric current!
The machine must be switched off and secured against being switched back on unexpectedly/accidentally.



WARNING!

Lifting tipper:
If maintenance work is required below the raised, empty lifting platform, the area may only be entered when the machine is stationary and the main switch is secured / the mains plug is disconnected.



WARNING!

Only trained specialists may carry out maintenance work on moving parts.
Danger due to falling components
The components should be checked as to proper seating after any maintenance or installation.





WARNING!

Sufficient lighting must be available when carrying out maintenance or repairs.



WARNING!

In the event of irregular noises or strong abnormal vibrations, switch off machine and rectify the cause.



WARNING!

Check the earthing of the machine when carrying out servicing.
Damage should be repaired immediately.
Danger of electric shock!



CAUTION!

Warning of hot surfaces on the machine (motors, transmissions, auxiliary drives)
Danger of burns or scalding!
Wear special work clothes. Allow the machine to cool down after use



CAUTION!

Shut off the flow and return lines of all media (water, air) on-site and disassemble and bleed the cleaning agent supply line when carrying out maintenance or repair work.
Personal protective clothing should be worn (facial and body protection, protective gloves, etc.).



CAUTION!

Spilled lubricants must be removed immediately.

Danger due to falling!



NOTICE!

Inspect the inside of the bowl for foreign bodies and defects on the tools before and after operation.



WARNING!

After turning off the main switch electrical components can still be energized.

Substantial risk of injury from electric shock!

Work on the electrical installation of the machine may only be carried out by a specialist.

For maintenance and repair work on the electrical installation, the machine must be completely disconnected from the power supply.



8.3 SECURITY CHECK

i NOTE!

The functionality of the protective devices must be checked regularly. For further information see the maintenance chapter “Safety checks”.

i NOTE!

The limit switches and assemblies of the protective devices must be replaced every 15 years to ensure they work safely!

Assembly	Work to be completed	Service interval Months				
		daily	1	3	6	12
Emergency stop button	Actuate emergency stop button → The movement of the machine must stop immediately		X			
Limit switch „Tong lock closed“ (bowl inserted)	The limit switch must switch reliably with gripped bowl. → Without a bowl the limit switch must not switch		X			
Limit switch “Bowl inserted” (without tong lock)	Function test by inserting the bowl → Both limit switches must switch (become free) before reaching the end position	X				
	Function test by starting the elevator tipper without the bowl → The lifting platform of the elevator tipper must not be raised	X				
Safety cage	Open safety cage while machine is running → The movement of the machine must stop immediately		X			
Light curtain	Interrupt light curtain while machine is running → The movement of the machine must stop immediately	X				
Safety bar	Actuate safety bar while machine is running → The movement of the machine must stop immediately	X				
Drop prevention	The drop prevention lever must move to and fro smoothly while the lifting platform moves up and down.		X			

8.4 MAINTENANCE PLAN ELEVATOR TIPPER HK1200



NOTICE!

The maintenance intervals presume normal ambient conditions. Shorter maintenance intervals are required under extreme operating conditions, e.g. high humidity, aggressive environmental conditions and wide temperature fluctuation.



MAINTENANCE SCHEDULE ELEVATOR TIPPER HK1200

12000										6 years	
6000		1		5						3 years	
2000				4			10			yearly	
1000						11	12			6 month	
160										weekly	
	8	8	9		2	6			13	9	daily

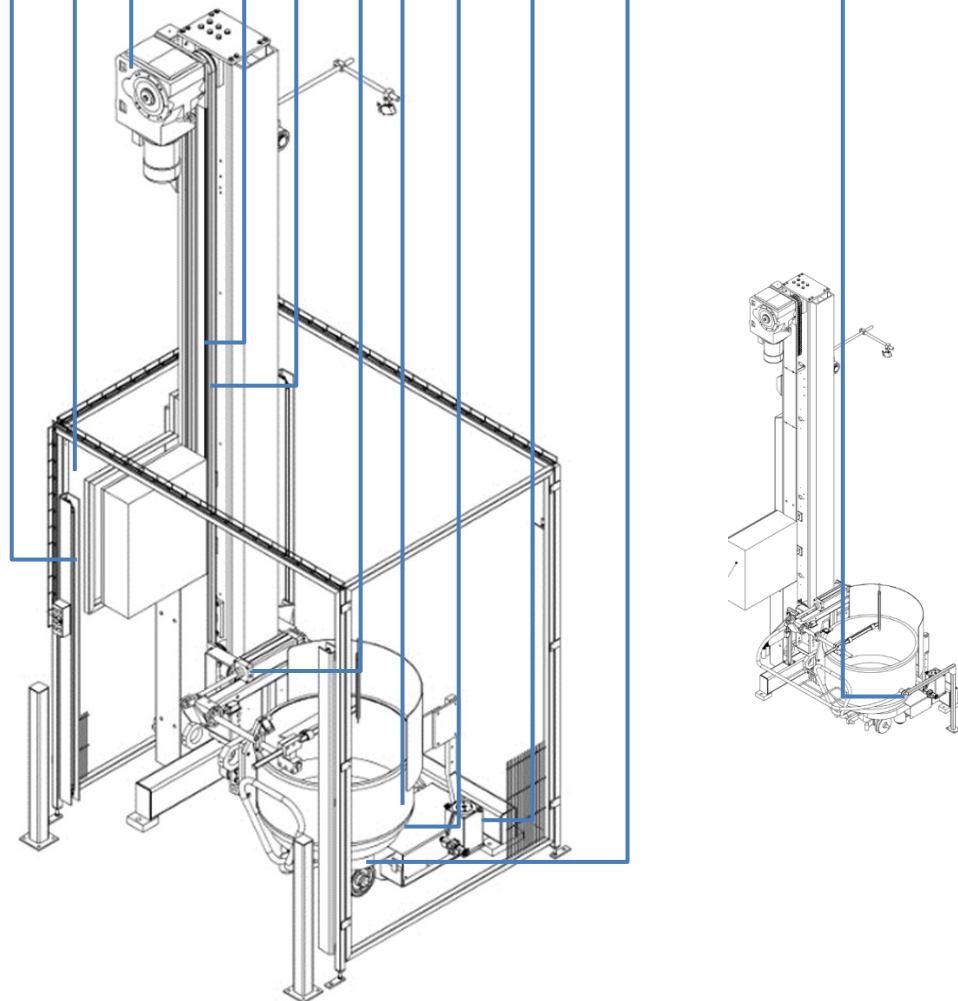



Figure 8-1 | Maintenance points Elevator Tipper HK1200

	Maintenance point	Works to be done
1	Geared brake motor (Filling volume):	16.5 l, complete overhaul by skilled person
2	Guide rails	Cleaning Dirt may not accumulate on the guide rails
3	Contaminants (including flour) must be removed from the guide rails. Contaminations considerably reduce the service life and may result in a loss of the warranty.	
4	Chain	Check tension and adjust, if necessary
	Measure the chain wear over 20 links (roller chain according to DIN8187, division 31,75, approved wear equals 3% Nominal dimension: 635mm Maximum dimension: 654mm (use chain gauge)).	
5	Chain	Check tension and adjust, if necessary
6	The lever of the mechanical fall arrester must be able to easily move back and forth during the up and down movement of the lifting platform.	Clean and grease, if necessary see also chapter 'Safety devices'
7	Safety bow link	1 x 2 cm ³ grease
8	Safety cage gate (not illustrated)	Check of function
9	Safety cage light curtain	See check of the light curtain
10	Hydraulic unit	see 'Hydraulics'
11	Claw bolts	2 x 2 cm ³ grease
12	Hydraulic cylinder	2 x 1 cm ³ grease
13	clamping surface of the claw	Thin grease film, prior cleaning
daily	Check of the safety devices	See 'Safety control'
daily	Cleaning	See 'Cleaning'

The indicated oil quantities are approximate quantities. The gearboxes must be refilled or filled up to the oil level mark after refilling or oil change.

i NOTE!

The maintenance points (7) bis (13) apply to optional equipment.

8.5 MAINTENANCE OF THE HYDRAULIC SYSTEM

8.5.1 SAFETY INSTRUCTIONS



DANGER!

Check the hydraulic system for tight fit and leak tightness after maintenance work at the hydraulic system, especially with loosening fittings.



WARNING!

Do not loosen fittings, connectors or equipment as long as the machine is still pressurized.

Depressurize the hydraulic system prior to maintenance.



NOTICE!

Dirt or liquids entering the hydraulic system can lead to faults; in that case, secure function of the hydraulic system or its components cannot be ensured.

Maintain utmost cleanness when working on the hydraulic system!

8.5.2 CHECK THE HYDRAULIC OIL LEVEL

- Shortly after start-up
- Weekly later on



NOTICE!

The oil level varies while the hydraulic system is working. The oil level must stay inside the markings; especially a too low oil level can lead to breakdown of the hydraulic pump due to cavitation.

8.5.3 MAINTENANCE HYDRAULIC OIL

Maintenance intervals depend on the following operation factors:

- Condition of the hydraulic oil (e.g. water entered the oil, used up oil)
- Operating temperature
- Fill level

i NOTE!

DIOSNA recommends an oil change according to an oil analysis.

Change the hydraulic oil of machines with no oil analysis after 2000 at latest after 4000 operating hours.

- Perform the oil change and refill at operating state temperature.
- Re-filling of new oil does not improve used up or soiled oil!
- Use the system filter or a filter with at least the same deposition rate when filling in new oil.
- Take oil samples and have them analyzed for sort, size and quantity of particles.
- Document the analyzed data.

Ensure to drain the used up oil completely at an oil change; therefore pay attention to the piping and the oil consumers. If necessary, vent hydraulic system.

8.6 NOTES FOR THE (OPTIONAL) LIGHT CURTAIN

8.6.1 SAFETY ADVICES



DANGER!

Hazard due to lack of effectiveness of the protective device

Persons and parts of the body to be protected may not be recognized in case of nonobservance.

- Maintenance work, alignment work, fault diagnoses, and any changes to the integration of the protective device in the machine must only be carried out by qualified personnel.
- The effectiveness of the protective device must be checked following such work.

**DANGER!**

Hazard due to lack of effectiveness of the protective device

Persons and parts of the body to be protected may not be recognized in case of nonobservance.

- Make sure that the optical properties of the front screens of the sender and receiver are not changed e.g. by beading water, mist, frost or ice formation.
- Make sure that all reflective surfaces and objects maintain a minimum distance from the protective field.
- Make sure that no dispersive media (e.g., dust, fog, or smoke) are within the calculated minimum distance from the protective field.

8.6.2 DAILY CHECK

CHECKING THE EFFECTIVENESS

The effectiveness of the protective device must be checked daily according to manufacturer information.

**DANGER!**

Hazard due to lack of effectiveness of the protective device

Persons and parts of the body to be protected may not be recognized in case of nonobservance.

**DANGER!**

Hazard due to unexpected starting of the machine

- Make sure that the dangerous state of the machine is (and remains) switched off during the check
- Make sure that the outputs of the safety light curtain have no effect on the machine while checking the components.

8.6.3 MAINTENANCE OF THE (OPTIONAL) LIGHT CURTAIN

The safety light curtain is maintenance-free. Depending on the ambient conditions, regular cleaning is required.

In addition, observe the instructions of the manufacturer of the protective device.



DANGER!

Risk of ineffectiveness of the protective device

Persons and parts of the body to be protected are not recognized in case of non-observance.

- Regularly check the degree of contamination on all components according to the operating conditions.
- Do not conduct any repairs on the device components (sender, receiver).
- Do not open the device components.

8.6.4 REGULAR INSPECTION OF THE DES (OPTIONAL) LIGHT CURTAIN



DANGER!

Risk of ineffectiveness of the protective device

Persons and parts of the body to be protected are not recognized in case of non-observance.

- The checks must be carried out by qualified safety personnel or specially qualified and authorized personnel and must be recorded and documented to ensure that the tests can be reconstructed and retraced at any time.

Check the machine following the inspection intervals specified in the national rules and regulations. This procedure ensures that any changes to the machine or manipulations of the protective device are detected after initial commissioning.

Check the machine again according to the checklist in the appendix, see Checklist for initial commissioning and commissioning:

- If changes are made to the machine or protective devices (e.g. changes to the mechanical, electrical, optical connection)
- If sender or receiver have been replaced

8.6.5 MAINTENANCE OF LIMIT SWITCH “BOWL INSERTED” CROSS-WISE TIPPER, WITHOUT TONG LOCK

The limit switch, the switch rod and the switch roller which is attached at the end of the switch rod must be set so that a reliable switching function is guaranteed in the inserted state. For information on the settings see the end of this chapter.

i NOTE!

When the bowl carriage is inserted, the limit switch “Bowl inserted” must no longer be enabled.

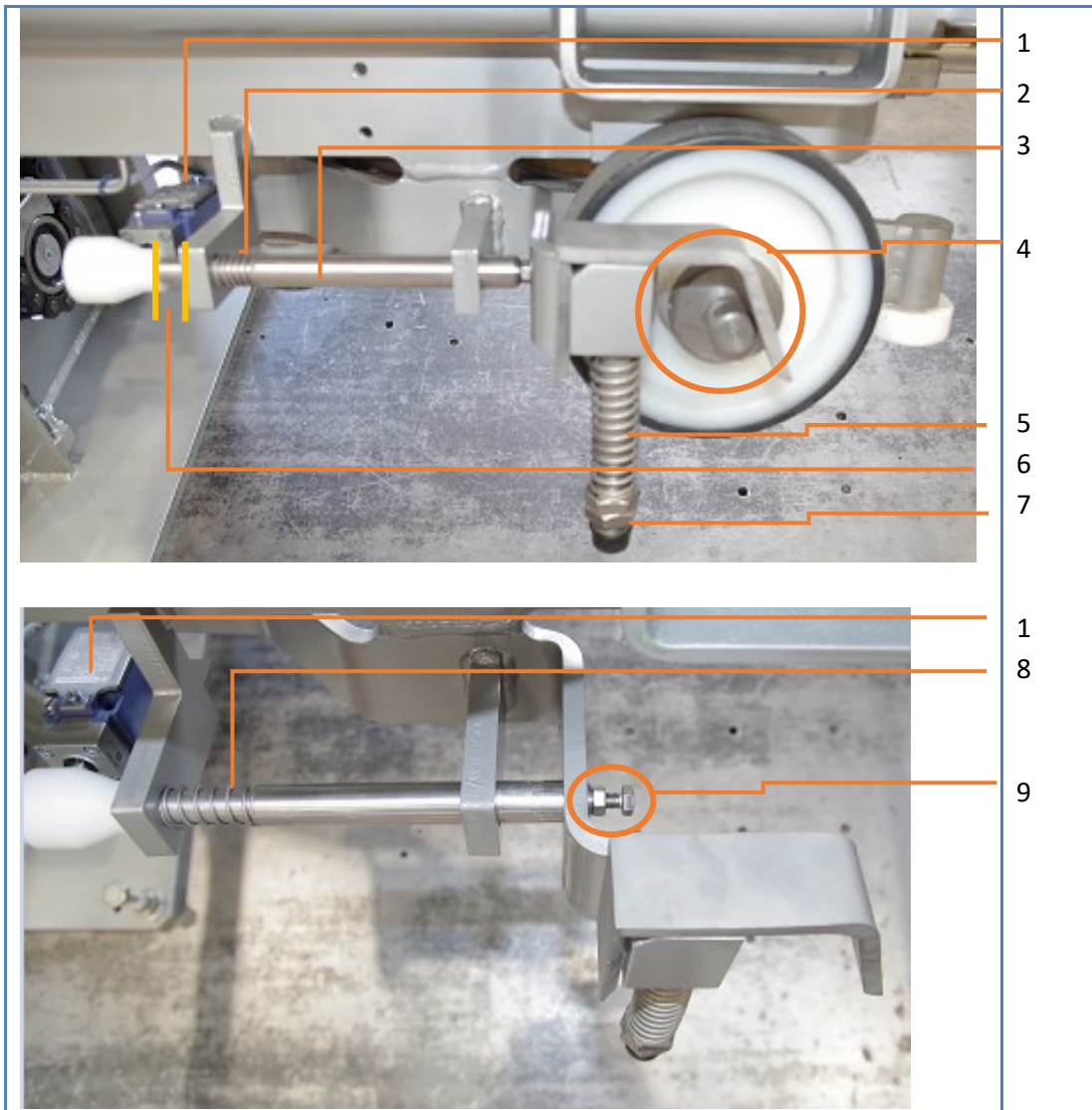

Figure 8-1 | Overview of limit switch “Bowl inserted”

Position	Description
1	Limit switch “Bowl inserted”
2	Spring switch actuation, actuated
3	Switch rod
4	Securely locked bowl trolley
5	Spring for catch actuation
6	Switching distance Switch rod actuated
7	Nuts for setting the preload Spring for catch actuation
8	Switch actuation spring, unactuated
9	Switching distance adjustment screw

Assembly	Work to be completed	Service interval Months				
		Daily	1	3	6	Other
Limit switch “Bowl inserted”	Check smooth running of the switch rod (3)	X				
	Function test by pressing in the switch rod (3)	X				
	Visual inspection for breakage or damage of the springs (2) (5)		X			
	Check of specified dimensions according to drawing, see below.				X	
	Replacement of springs (2) (5) ⚠ Both springs must be replaced. The replacement interval can be modified by the customer on the basis of experience.				X	
Limit switches and assemblies of the safety functions	The limit switches and assemblies of the protective devices must be replaced every 15 years to ensure they work safely. See .					15 years

SETTINGS FOR LIMIT SWITCH “BOWL INSERTED” – BOWL CARRIAGE INSERTED

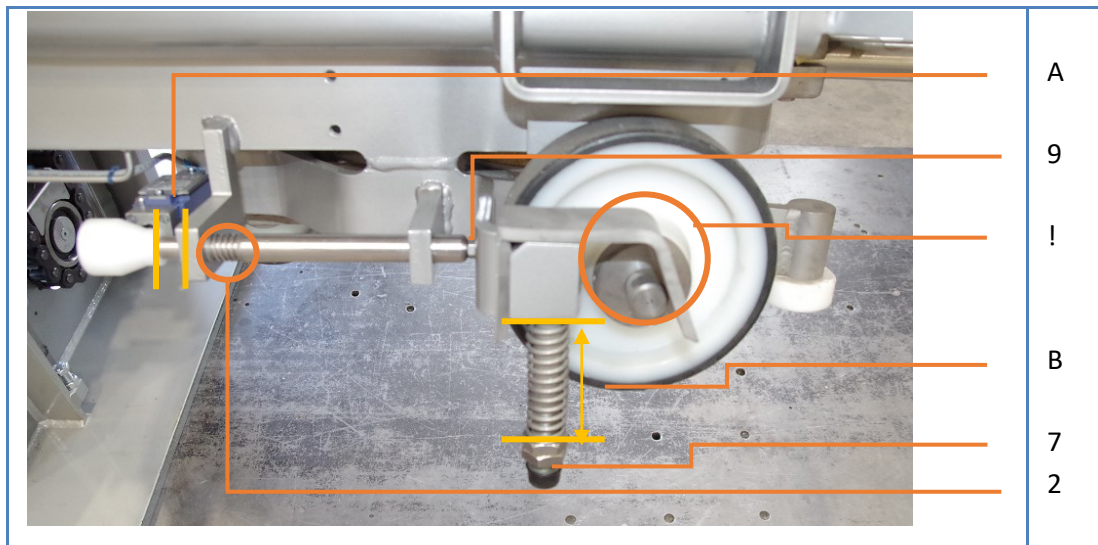

Figure 8-2 | Limit switch “Bowl inserted” – Bowl carriage inserted

Position	Description
!	⚠ The bowl carriage must be securely locked in the inserted state.
A	The distance of the switch rod with the inserted bowl carriage is approx. 20 mm. The spring (2) must not be fully compressed. → The distance is set via the screw and nut on the switch rod (9).
B	The length of the pretensioned spring is approx. 90 mm in the locked state. → The spring pretension is set using the two nuts (7)

SETTINGS FOR LIMIT SWITCH “BOWL INSERTED” – BOWL CARRIAGE NOT INSERTED

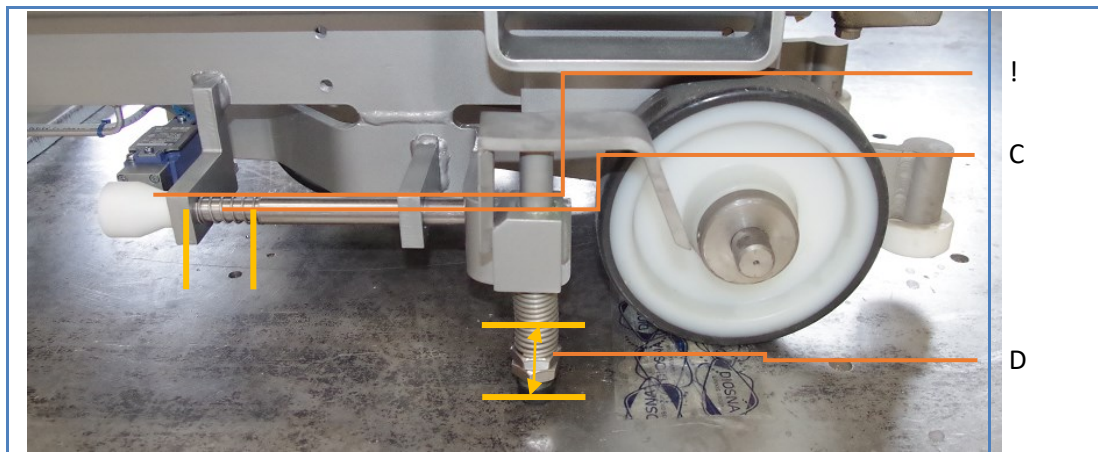

Figure 8-3 | Limit switch “Bowl inserted” – Bowl carriage not inserted

Position	Description
!	⚠ The limit switch “Bowl inserted” must be actuated.
C	The distance of the switch rod without bowl carriage is 45 mm. → The distance is set via the screw and nut on the switch rod.
D	The length of the pretensioned spring is 46 mm in the unlocked state. → The spring pretension is set using the two nuts.

8.7 LUBRICANTS

8.7.1 GENERAL

Properly selected lubricants contribute significantly to achieving a good work performance as well as a longer service life of the machine and help to eliminate downtimes. The lubricants listed have proven successful and are selected based on the prevailing working conditions at the lubrication points.

8.7.2 LUBRICANT RECOMMENDATION

DIOSNA uses lubricants that meet the requirements of the NSF-H1 registration. The lubricants listed in the lubricant recommendation are used for the initial filling.

Avoid the usage of recycled oil.









NOTICE!

Prior to the use of other lubricants, test the equality of the tribological properties and the miscibility with the lubricant manufacturer!



8.7.3 LUBRICANTS ELEVATOR TIPPER HK1200

Lubrication point	Lubricant	
Bearing	Klüber Klübersynth UH1 64-62	
Fitting bolts, Slipping surfaces	Autol Top 2000 (not acc. to NSF-H1) Klüber Klübersynth UH1 14-151	 
Guiding carriage, Guiding rails	Grease according to DIN 51825, consistency class NLGI 2 according to DIN 51818, Greases with a solid lubricant content (such as graphite or MoS2 must not be used!	
Main drive	Castrol Tribol Foodproof 1800/460 or CLP PAO ISO VG 460 see type plate	
Bowl drive (Option)	Aral Eural Gear 220	
Hydraulic unit (Option)	Klüber Klüberfood 4 NH1-32	

8.8 WEB-LINKS TO THE SUPPLIERS DOCUMENTATIONS

BAUER LIFTING MOTOR FROM BAUER
Elektromotoren GmbH

<http://www.bauergears.com/products/Geared-Motors/BK-Series>

SEW DRIVE MOTORS FROM SEW
EURODRIVE

<https://www.sew-eurodrive.de/os/dud/?tab=documents>

Rexroth HYDRAULIC UNIT
Bosch Group

<https://www.boschrexroth.com/en/xc/products/product-groups/industrial-hydraulics/power-units/power-units-3#>

SICK LIGHT CURTAIN FROM SICK

Light curtain deTec4 Core

https://cdn.sick.com/media/docs/0/10/010/operating_instructions_detec4_core_de_im0048010.pdf

KEYENCE LIGHT CURTAIN FA. KEYENCE

Light curtain GL-R96H

https://www.keyence.de/download/download/confirmation/?dlAssetId=AS_48801&dlSeriesId=WS_SR54488&dlModelId=&dlLangId=&dlLangType=de-DE

MAINTENANCE UNIT AND PNEUMATIC COMPONENTS FROM
FESTO

https://www.festo.com/cat/de_de/data/doc_engb/PDF/EN/LFR-D-MPA_EN.PDF

9 FINAL SHUTDOWN AND DISPOSAL

9.1 SHUTDOWN

Decommissioning as follows:

1. Lower the lifting platform
2. Switch off main switch
3. Switch off supply media.



NOTICE!

For longer downtimes, suitable measures are to be taken for corrosion protection.



9.2 FINAL SHUTDOWN AND DISPOSAL

When the machine reaches the end of its service life, it must be sent for proper disposal.



CAUTION!

Warning of hazardous substances!

Hazardous substances can pollute soil and groundwater or can get into the sewage system.

For all works on the machine and using the machine, make sure that the legal obligations for waste avoidance and for proper recycling and disposal will be fulfilled.

Especially with installation, maintenance and repair works, water polluting substances, e.g. chemicals, lubricating grease and oil may not pollute the soil or get into the sewage system.

These substances must be stored, transported, collected and disposed of in suitable containers.



**CAUTION!****Electrical and electronic waste**

Devices with this logo on their packaging or on the device itself must be disposed of separately. These devices may not be disposed of via the usual domestic waste.

You are responsible to ensure that each electrical and electronic piece of waste will be disposed of via the competent organizations, e.g. local civic waste collection point.

**NOTICE!**

Observe current legal provisions when disposing of lubricants.



9.2.1 CHEMICALS, OIL AND OIL-BEARING WASTE, GREASE

Chemicals, oil and oil-bearing waste, as well as grease pose a high risk to the environment. Therefore, specialized companies shall dispose of them.

Lead the waste materials to a specialist company for disposal.

9.2.2 METALS AND PLASTIC MATERIALS

Metals and plastic materials must be assorted as well as possible.

Lead the waste materials to a specialist company for disposal.

10 TROUBLESHOOTING





DANGER!

Trouble-shooting that requires removal of the protective devices or cover panels using tools may only be performed by specialists.

GENERAL FAULTS

Fault	Reason	Remedy
Machine does not start	Main fuse has triggered	Check, measure voltage, replace if necessary
	Control fuses	Switch on, measure voltage, replace if necessary
	Main switch not switched on	Switch main switch on
	No setpoint values set	Set setpoint values
	Emergency Stop has been actuated	Release Emergency Stop push-button
	Connection cable not connected properly.	Check the electrical connection by a specialist
	Mains plug disconnected (for machines with plug).	Plug in the mains plug
Process is interrupted	Motor protection has triggered	Overload If it triggers repeatedly, reduce batch
	Main fuse has triggered	Electrical defect Fuse too small (only use slow to blow fuses)
	Emergency Stop has been actuated	Release Emergency Stop push-button
	Connection cable has been disconnected	Check the electrical connection by a specialist
	Mains plug disconnected (for machines with plug).	Plug in the mains plug
After the time has been expired: Machine does not stop	Control defective	Switch the main switch off and lock it Remedy control problems

ELEVATOR TIPPER TYPE HK1200

Malfunction	Cause	Remedy
Machine does not start	Safety bow not closed	Close safety bow
	Gate of the safety gate not closed	depends on the design elevator Close gate
	The protective area of the light curtain is accessed	Leave safety area
	Light scanner above the hopper (or dough container) has not released (if existing)	Hopper is not emptied Empty the hopper
		Light scanner is not set correctly Check the settings and the scanning distance
Light scanner defective Check the light scanner and replace if necessary		
Clamp does not open (only for lifing platforms with clamping device)	Proximity switch has not switched	Check the proximity switch
	Hydraulic unit does not run	Check the hydraulic unit
Process is interrupted	Motor protection has activated	 The elevator has driven against an obstacle Immediately clear the fault by a qualified technician THE MACHINE MUST NOT BE OPERATED WITHOUT TROUBLESHOOTING.
		 Maximum load exceeded. The maximum load capacity - see "Technical/Performance data" - must not be exceeded.
	Safety bow lifted	Close again safety bow
	Gate of the safety cage is open	depends on the design elevator Close again gate
	The protective area of the light curtain/Laser scanner is accessed	Leave again the protective area